

For Physiological Experiments



Prevents Vibration and Protects Living Cell Specimens

Olympus fixed-stage microscopes are designed to meet a high standard of stability and reliability in electrophysiological applications. Each microscope has a range of features to mitigate and prevent vibration as well as innovative technologies that make patch clamp operations more efficient.

Combined with Olympus' renowned UIS2 optics, our fixed-stage microscopes offer high levels of quality in performance and ease of use.

Front operation and reduced vibration for improved operability and stability

IR-DIC and IR oblique illumination condenser for deep-section observation

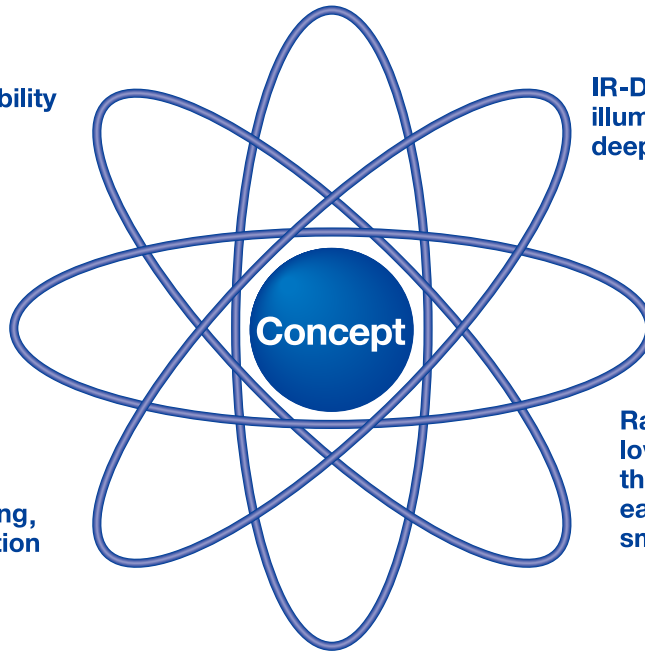

High NA objective offering excellent performance in IR-DIC observation, membrane potential imaging, and fluorescence observation

Raising the objective and lowering the stage of the microscope enables easier experimentation on small animals

Fluorescence macro objectives for membrane potential observation



BX51WI with Luigs & Neumann Accessories.*

*The unit from third-party suppliers is included in the above system.



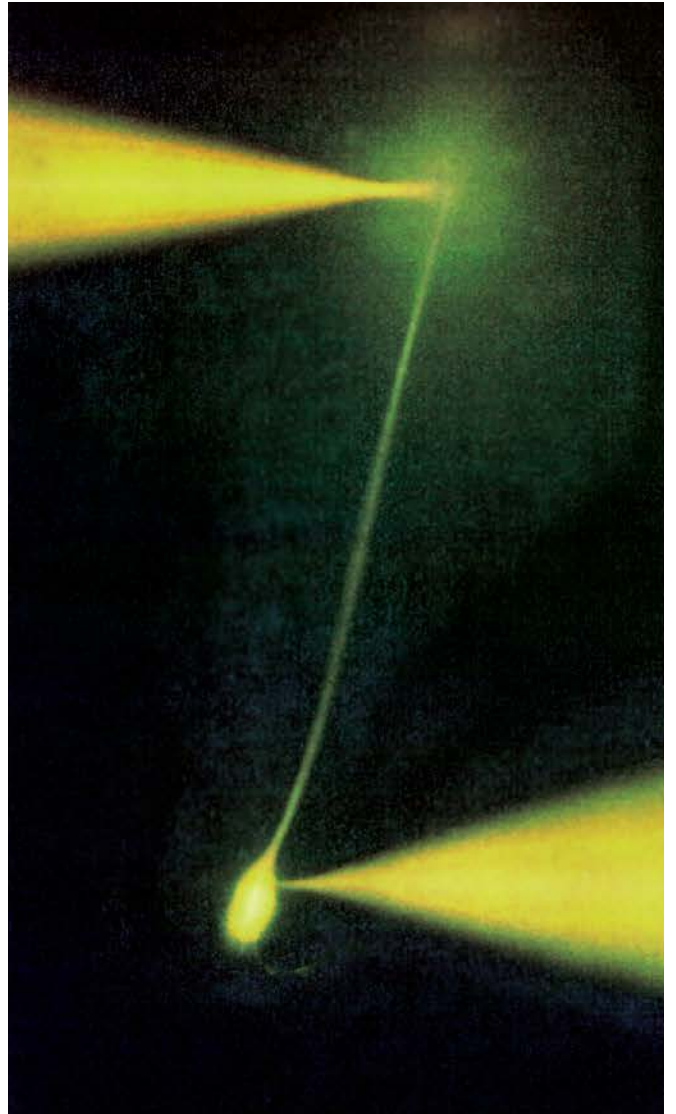
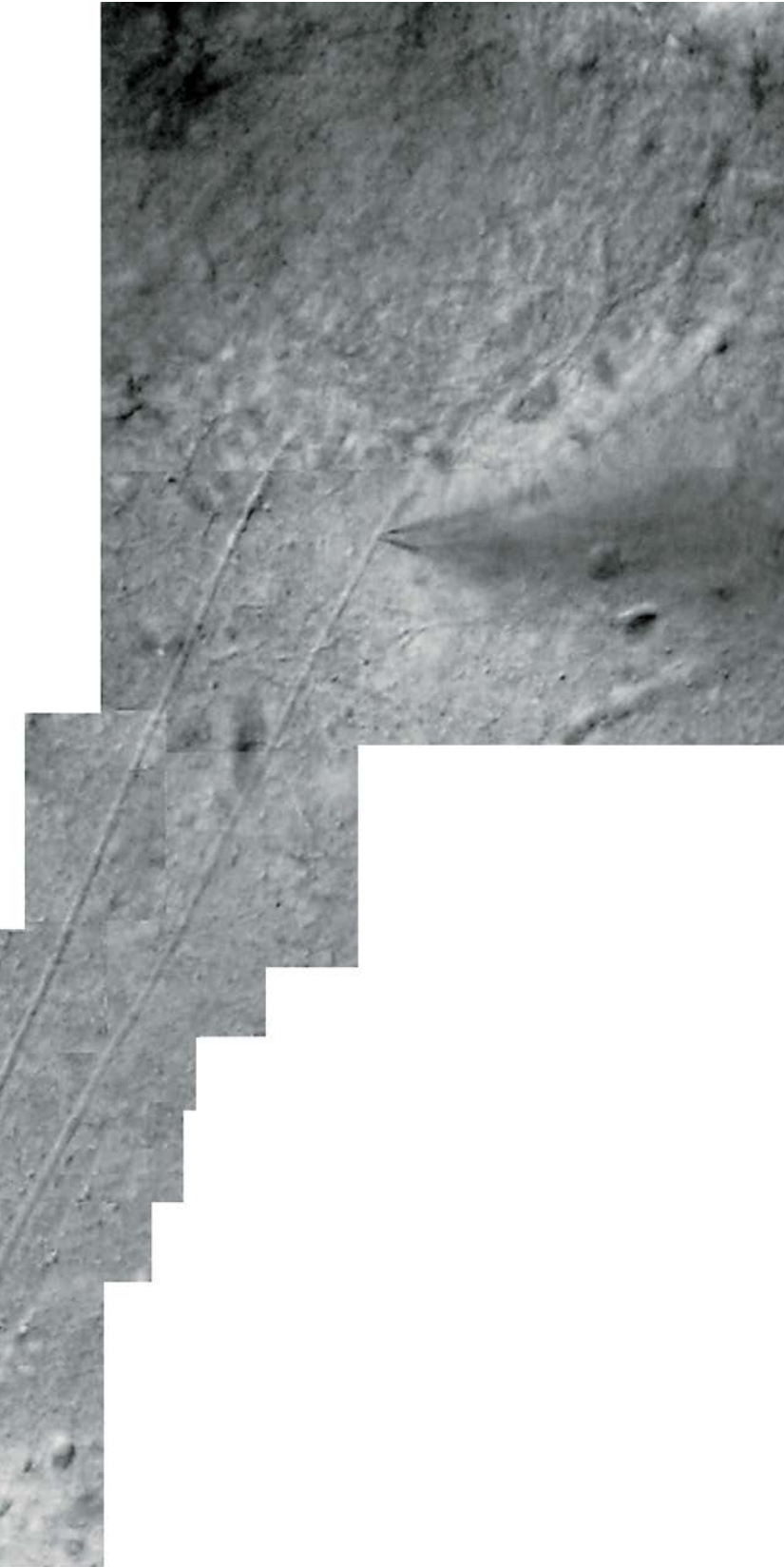

Front Operation with No Vibration and Minimal Noise

Open space ideal for experiments

The front operation system prevents interference in patch clamping work.

The design is simple and enables frequently performed operations such as focusing or filter exchange to be done easily at the front of the unit.

Ample space is provided on both sides of the microscope frame and condenser, so the necessary manipulation equipment can be positioned close to the microscope.

❶ Vibration-free shutter

The fluorescence shutter slides horizontally with no detents and no vibration.



❷ Mirror unit turret with adjustable click release

The click-stop on the 6-position turret can be released with a precision screwdriver.



❸ Ample space around the condenser

The frame has ample space around the condenser, making it easy to adjust Nomarski DIC contrast, exchange filters, adjust the condenser's aperture stop, and to easily switch between visible light, Nomarski DIC, or IR-DIC.



❹ Front focus knobs close to the operator's hand

Fine focus control is located at the front on both sides of the microscope body. The knob on the right integrates both coarse and fine focus control.

❺ Coarse focus lock lever

When engaged at the desired position, the objective can be raised with the coarse focus knob and then returned precisely to its original position.



❻ A Waterproofing sheet

A waterproofing sheet, attached by the supplied magnets, provides protection against liquid overflow and spills. The sheet is large enough to protect the frame, condenser, and focusing mechanisms.

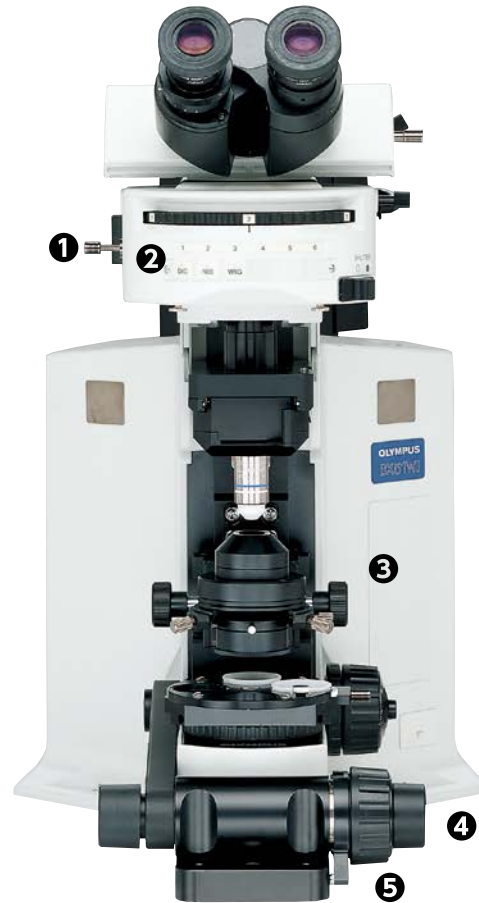

We offer a range of nosepieces for different applications



Swing nosepiece WI-SRE3

The slim, compact design and front-to-back swing motion permits objective changes without interfering with electrodes and micromanipulators. Objective positioning incorporates a vibration-free counterspring mechanism.



Slide nosepiece U-SLRE

This nosepiece is designed for the attachment of one large diameter, low magnification fluorescence objective (XLFLUOR 2X/340 or 4X/340) and one objective with normal (RMS) diameter threads. Nosepiece motion is a simple horizontal slide.



Single position nosepiece WI-SNPXLU2

Designed to accept the unique, large-diameter XLUMPLFLN20XW objective.



RMS adaptor WI-RMSAD

This adaptor enables the attachment of an objective with RMS thread size to the WI-SNPXLU2.

Flexible for a Wide Variety of Needs

Experiments with small animals

Raise the objective and lower the stage to enable small animal experiments

The arm height raising kit (WI-ARMAD) provides an additional 40 mm of clearance and is mounted between the microscope frame and the reflected light illuminator. Small animal experiments usually do not require transmitted light, thus allowing the removal of the substage condenser assembly. After removal, the stage may be lowered an additional 50 mm, providing a total clearance increase of 90 mm.



Normal configuration

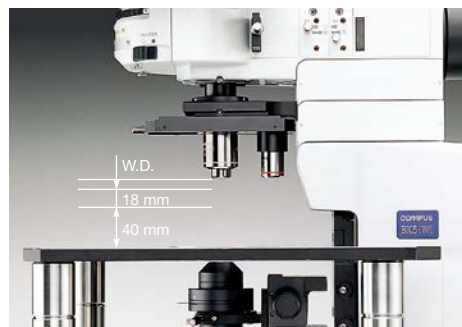

40 mm more clearance via WI-ARMAD



Detaching the condenser assembly and lowering the stage by 50 mm provides maximum clearance

Outstanding Image Clarity for Electrophysiological Experiments

IR-DIC/ Nomarski DIC observation

IR-DIC optimized optics:

Designed for observations at 775 nm to 900 nm

Thanks to the precisely aberration-compensated IR-DIC optics that cover from visible to near-infrared light of 775 nm/900 nm wavelength, the clarity of images observed under near-infrared light has been improved still further, offering clear observation of even deep sections of a brain slice.

- **Visible light DIC**

Enables high-resolution observation of the tissue surface.

- **775 nm IR-DIC**

In combination with an IR camera, it enables observation within the tissue slice. Optics are corrected for visible and IR wavelengths, allowing fast switching between wavelengths with minimal refocusing.

- **900 nm IR-DIC**

Enables observation deeper into the tissue (requires special polarizer and analyzer optimized for 900 nm).

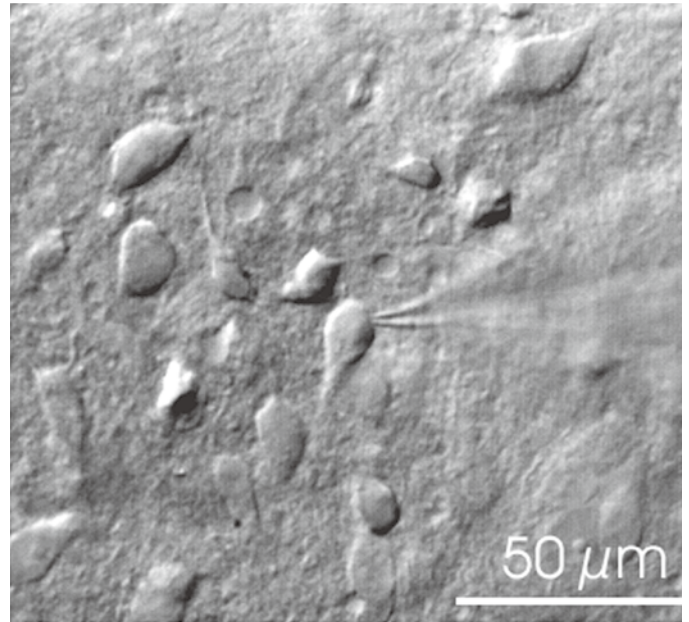

Nucleus of solitary tract from slice of rat medulla oblongata (thickness: 400 μm)
Prof. Fusao Kato
School of Medicine Physiology Dept.,
Jikei University
Kato & Shigetomi, J. Physiol. (2001), 530: 469-486

Senarmont compensation for Nomarski DIC observation

When using a Senarmont-equipped condenser, all contrast adjustments are performed with the 1/4 wave plate below the condenser, eliminating the risk of bumping the stage, specimen, manipulators, or nosepiece.

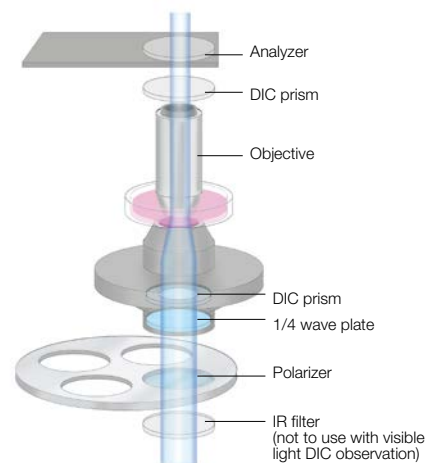

Oblique illumination observation

Oblique observation optimizes contrast by changing the direction of the specimen shadow

Our oblique condenser (WI-OBCD) has a long working distance that enables users to alter the angles of shadows by 360 degrees without moving the specimen. Requiring no additional accessories, oblique illumination is easy to set up and control. Plastic dishes (normally unsuitable for all types of DIC) are easy to image with oblique illumination. The oblique illumination slit aperture is variable in size and on a slider, allowing quick changeover.

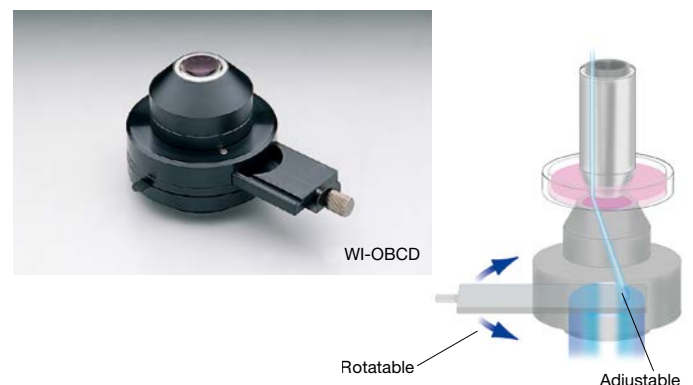

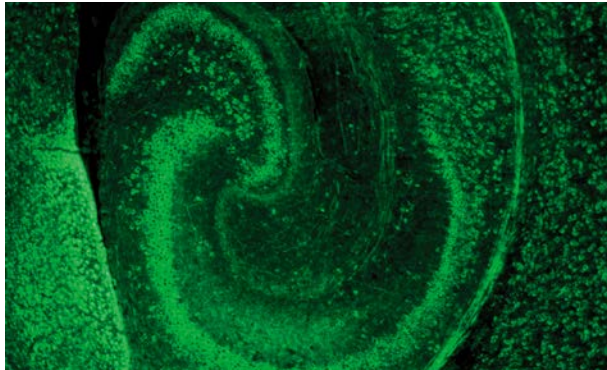

Transverse cryostat section through the hippocampus of a mouse at postnatal day 10 was stained with a mouse monoclonal anti-neurofilament-L (Chemicon, MAB1615) . An FITC-conjugated anti-mouse antibody was used for detection of NF-L. Objective: XLFLUOR4X/340

Masaharu Ogawa, Ph.D
Laboratory for Cell Culture Development, Brain Science Institute, Riken

Fluorescence macro observation

2X and 4X macro lenses with high numerical apertures provide fluorescence images
Designed for GFP imaging of large cells, such as neurons

2X and 4X low magnification fluorescence objectives and a special GFP observation mirror unit are available. The objectives have a long working distance for maximum flexibility.



Observing changes in membrane potential

Measuring changes in membrane electric potential using the XLUMPLFLN20XW objective with a 1.0 NA

The XLUMPLFLN20XW objective, with its high NA and 2.0 mm of working distance, enables measurement of cell membrane electric potential (as seen in the image on the right). Also, the 4X macro objective (XLFLUOR4X/340) can be used to measure membrane potential at the tissue level.

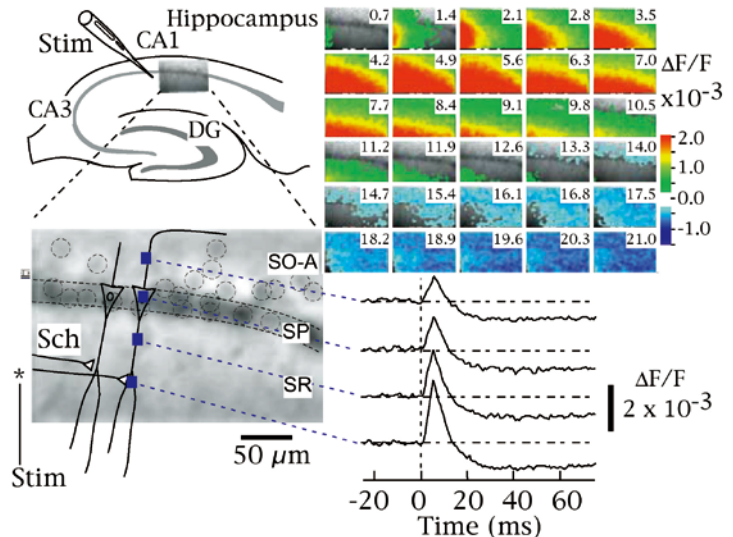

Imaging of neuronal activity with voltage sensitive dye

Spread of neural activity in area CA1 of acute rat hippocampal slice (400 μm thick) in response to a single stimulation applied to Schaffer collateral pathway imaged (at frame rate of 0.7 ms/frame) with a fluorescent voltage sensitive dye (VSD; Di-4-ANEPPS). The fluorescent image (90 x 60 pixels) captured by a digital high-speed CCD camera (MiCAM01, Brain Vision Inc.; with 20X super high NA objective and 0.5X adaptor) is superimposed on the illustration of a hippocampal slice (upper left panel). The image is enlarged and shown on the illustration of pyramidal cells (solid line) (lower left panel). Each laminar of CA1 is shown as follows: SO-A, Stratum oriens-alveus; SP, Stratum pyramidal; SR, Stratum radiatum. The individual somas of cells were visible (indicated by dotted circle on the image) and were found along the stratum pyramidal. The changes in the fluorescence of VSD (optical signal) in accordance with the membrane potential change upon a stimulation (Stim) onto Schaffer collateral (Sch) were pseudo-color encoded and shown as consecutive images (upper right panel; number in each image shows time from the stimulation (ms)). The depolarizing signal (red) spread along Schaffer collateral, which was followed by a hyperpolarizing signal (blue) originated in stratum pyramidal. The time courses of optical signals in representative pixels are shown in lower right traces.

Takashi Tominaga Ph.D, Brain-Operative Device Lab., Brainway Group, Brain Science Institute, Riken

* The above data were obtained using a forerunner to the XLUMPLFLN20XW, but the XLUMPLFLN20XW can be used to perform the same operations.

Accessories

Intermediate magnification changer U-ECA, U-CA

The U-ECA, which includes a 2X intermediate magnification position, enables quick magnification changes to a camera or observer without changing objectives. The U-CA includes a 4-position turret that allows rapid switching between 1X, 1.25X, 1.6X, and 2X positions. Both changers accept standard Olympus adaptors for attaching a wide range of cameras.

* U-ECA and U-CA are not recommended for IR observation with the U-TR30 trinocular observation head.



C-mount video magnification change unit (IR-compliant) U-TVCAC

The U-TVCAC includes a 3-position turret with 1X, 2X, and 4X IR-corrected positions. Includes a standard c-mount top port.



Objectives



Objectives		NA	W.D. (mm)	Visible light	775 nm	900 nm
No Cover Objective	MPLN5X	0.10	20.0	○	—	—
Long Working Distance No Cover Water Immersion Objective	UMPLFLN10XW	0.30	3.5	○	○	○
	UMPLFLN20XW	0.50	3.5	○	○	○
	LUMPLFLN40XW	0.80	3.3	○	○	○
	LUMPLFLN60XW	1.00	2.0	○	○	○
	LUMFLN60XW	1.10	1.5	○	○	○
Long Magnification Fluorescence Objective	XLFLUOR2X/340	0.14	21.0 (include 5 mm water)	○	○	—
	XLFLUOR4X/340	0.28	29.5 (include 5 mm water)	○	○	—
20X Super High NA Objective	XLUMPLFLN20XW	1.00	2.0	○	○	○

UMPLFLN-W/LUMPLN-W series water-dipping objectives provide a long working distance and 45° access angle, making these objectives well-suited for electrophysiology experiments. They have higher transmittance, from the UV to near IR range, and are applicable for IR-DIC or fluorescence imaging.

The LUMFLN60XW is a water-dipping objective with a high NA of 1.1, which is suitable for high-resolution fluorescence imaging. Adjusting its correction collar enables imaging of samples with a cover glass.

XLUMPLFLN20XW is a water-dipping objective with wide field of view and a high NA. Combining it with the optional intermediate magnification changer unit enables you to perform wide-field-of-view and high-resolution imaging.

XLFLUOR series objectives are high NA macro objectives with a long working distance. They enable fluorescence imaging at the tissue or organism level.

BX51WI Specifications

Optics			UIS2 optical system
Material			Aluminum
Illumination	BX51WI	Microscope body	Built-in Köhler illumination for transmitted light (FN 22), external light source, 12 V 100 W long-life halogen bulb (pre-centered) (average lifetime: approximately 2,000 hours)
		Light source TH4	Light adjustment: DC2.5 V ~ 12.6 V (continuous adjustment) 8.4 A max. Power consumption: 150 W, dimensions: 75 (W) x 125 (H) x 200 (D) mm (2.95 in. x 4.9 in. x 7.9 in.), weight 2 kg (4.4 lb)
Focus	BX51WI	Nosepiece focus by roller guide (rack & pinion) Stroke per rotation; fine: 0.1 mm coarse: 15 mm, maximum stroke: 25 mm Coarse lower limit stopper mechanism, Torque adjustment mechanism for coarse focus	
Nosepiece	WI-SRE3	Swing nosepiece	DIC prism: WI-DICTHRA, WI-DICT nosepiece arm: WI-NPA
	U-SLRE	Slide nosepiece	DIC prism: DIC observation is not available nosepiece arm: WI-NPA
	WI-SNPXLU2	Single position nosepiece	DIC prism: WI-DICTHRA, WI-DICT nosepiece arm: WI-NPA
Fluorescent Illuminator	BX-RFA	BX fluorescence illuminator, excitation balancer attachable, FS/AS detachable	
	BX-URA2	BX reflected light illuminator	
Observation Tube	U-TR30-2	Trinocular, FN: 22, inclination angle: 30°, interpupillary distance: 50 mm — 76 mm Light path exchange; 3 steps ① BI: 100% ② BI: 20% video, photo: 80% ③ Video, photo: 100%	
	U-ETR-4	Erect image trinocular, FN: 22, inclination angle: 30°, interpupillary distance: 50 mm — 76 mm Light path exchange; 2 steps ① Binocular: 100% ② Video, photo: 100%	
Stage	IX-SVL2	Mechanical stage, fixed to microscope body with WI-FSH, cross movement mechanism, X, Y axes handle torque adjustable (rack & pinion), movement range: 43 mm (Y) x 50 mm (X)	
	U-SVL(R)B-4	Used together with WI-STAD, cross movement mechanism, X, Y axes handle torque adjustable (rack & pinion), movement range: 52 mm (Y) x 76 mm (X)	
Long Working Distance Condenser	WI-UCD	Universal condenser, NA: 0.8, W.D.: 5.7 mm, with variable A.S. mechanism, turret: 4-position, four DIC prisms attachable Built-in quarter wavelength plate	
	WI-DICD	DIC condenser, one DIC prism attachable	
	WI-OBCD	Oblique condenser, built-in variable oblique illumination stop	

BX51WI Dimensions

(unit: mm)

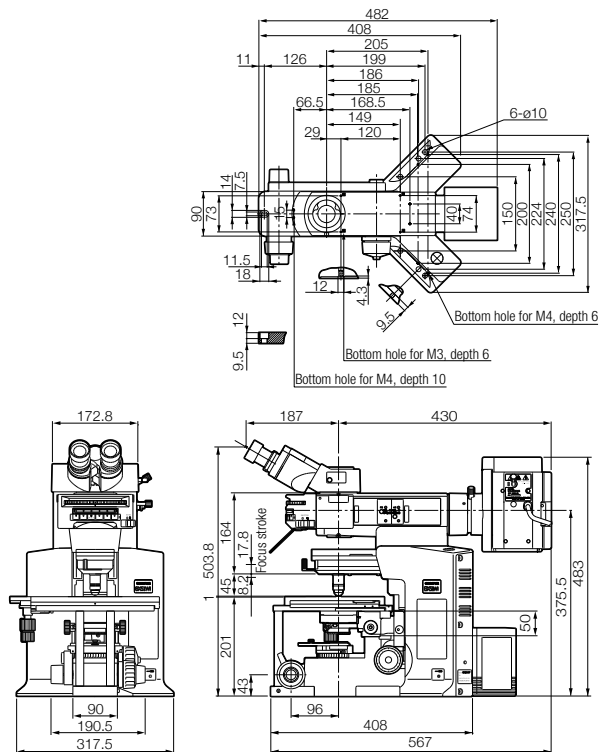

Weight: approx. 19 kg

BX2WI System Diagram

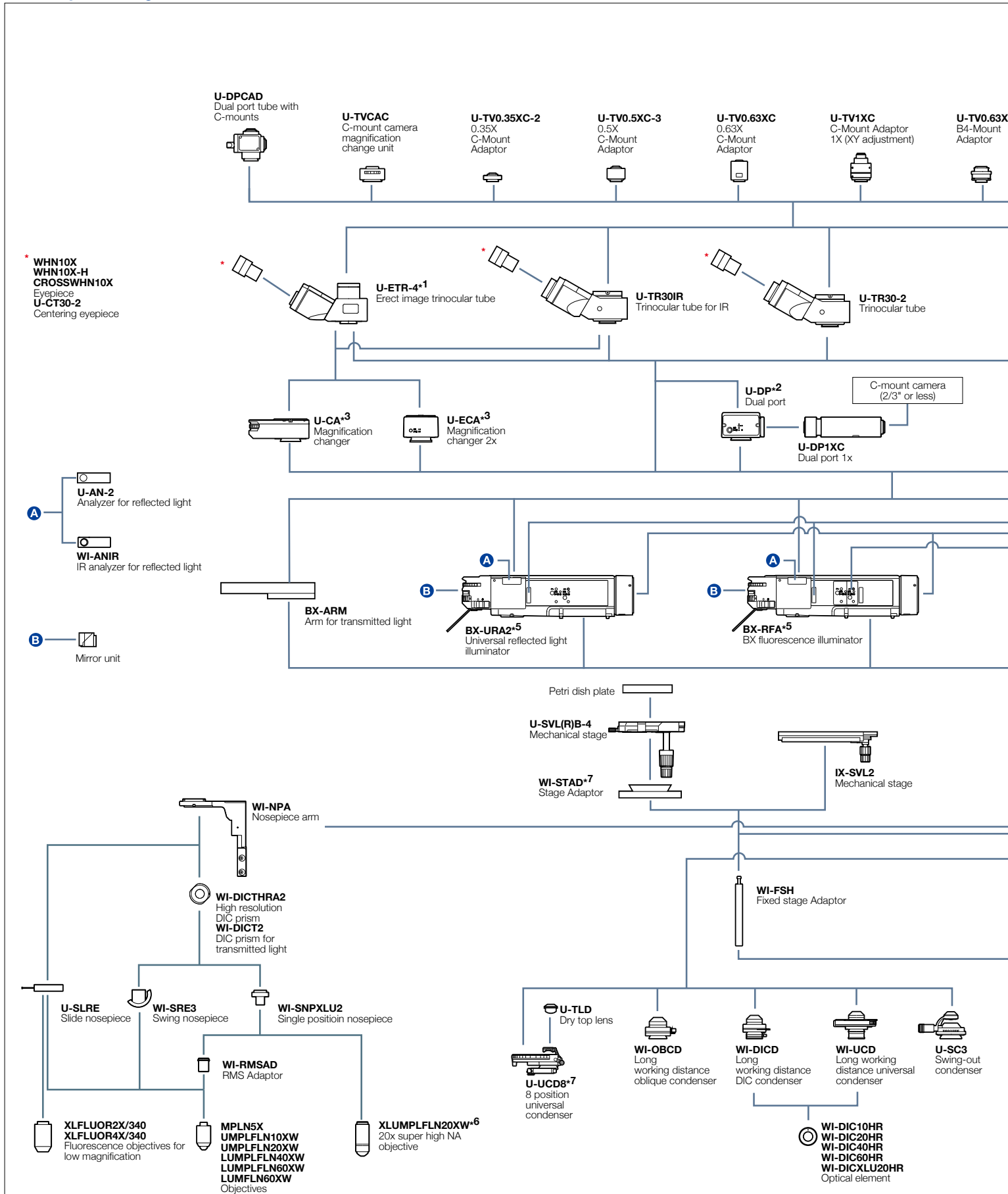

*1 Slight vignetting may occur in the periphery of the field of view in combination with an additional intermediate attachment. *2 Slight vignetting may occur in the periphery of the field of view in combination with fluorescence illuminator. *3 Can be used with U-ETR-4 and U-TR30IR. Field of view is limited when using more than two intermediate tubes. *4 Sub port can accept U-TV1X-2, and 2/3" or less CCD cameras.

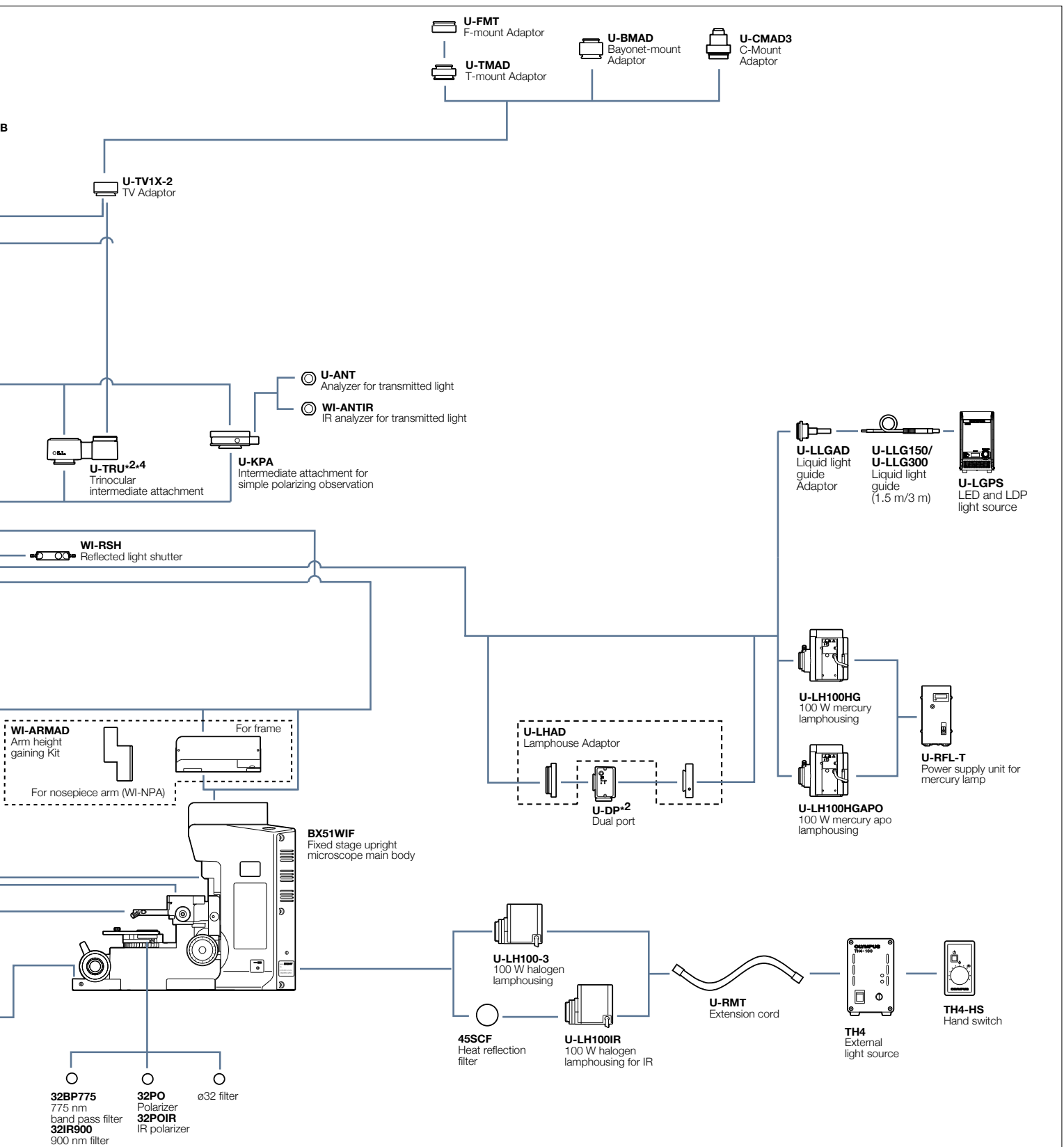

*5 FN is 22 when fluorescence observation. *6 Acceptable camera adaptors are U-TV1X-2, U-TVACA. *7 U-UCD8 cannot be used with WI-STAD.

- EVIDENT CORPORATION is ISO14001 certified.
- EVIDENT CORPORATION is ISO9001 certified.
- Illumination devices for microscope have suggested lifetimes.
Periodic inspections are required. Please visit our website for details.
- All company and product names are registered trademarks and/or trademarks of their respective owners.
- Specifications and appearances are subject to change without any notice or obligation on the part of the manufacturer.

EvidentScientific.com

EVIDENT

EVIDENT CORPORATION
Shinjuku Monolith, 2-3-1 Nishi-Shinjuku, Shinjuku-ku, Tokyo 163-0910, Japan

OLYMPUS